

AIR-AIR PRESSURE MULTIPLIER (BOOSTER)

The air-air pressure multiplier, or booster, is an automatic device that compresses air to give an outlet pressure that is double the inlet pressure. It is normally used to locally intensify the input pressure of one or more actuators. As it is entirely pneumatic it can be used when electric devices are not recommended. The booster can be supplied with or without a pressure regulator. It is fitted with check valves that maintain the outlet pressure even when the supply of compressed air is switched off. This means it is necessary to interrupt the supply and relieve the circuit before intervening on the device in any way. It is advisable to install a tank after the booster to prevent fluctuations in outlet pressure.



TECHNICAL DATA		Booster Ø 40	Booster Ø 40 with regulator	Booster Ø 63	Booster Ø 63 with regulator
Bore		ø 40		ø 63	
Fluid		Filtered unlubricated compressed air, Lubrication, if used, must be continuous.			
Threaded port		1/8"		3/8"	
Inlet pressure	MPa	0.2 - 1			
	bar	2 - 10			
	psi	29 - 145			
Outlet pressure	MPa	max 2	max 1.6 (regulated)	max 2	max 1.6 (regulated)
	bar	max 20	max 16 (regulated)	max 20	max 16 (regulated)
	psi	max 290	max 232 (regulated)	max 290	max 232 (regulated)
Operating temperature	°C	-10 to +60	-10 to +60	-10 to +60	-10 to +60
	°F	14 to 140	14 to 122	14 to 140	14 to 140
Weight	g	1.380	1.600	4.240	5.350
Mounting		Wall or panel			
Installation		In any position			

AIR-AIR PRESSURE MULTIPLIER (BOOSTER)

OPERATING LAYOUT

The pressure booster is comprised of a central body (with one 3-2 valve, one 5-2 valve and four check valves), two side liners and a through rod on which two pistons are mounted.

The supply air is compressed alternately by the two pistons in one of the two central chambers (B and C); the other central chamber and one of the two side chambers (A and D) operate the pistons; the external chamber, which is not involved in compression, is relieved.

Air compressed at a ratio of 2:1 passes through a check valve that maintains the output pressure even when compressed air is no longer supplied.

The valves in the central body, which are operated by mechanical pusher pistons, switch the function of the two pairs of chambers (A and D, B and C) at each piston stroke.

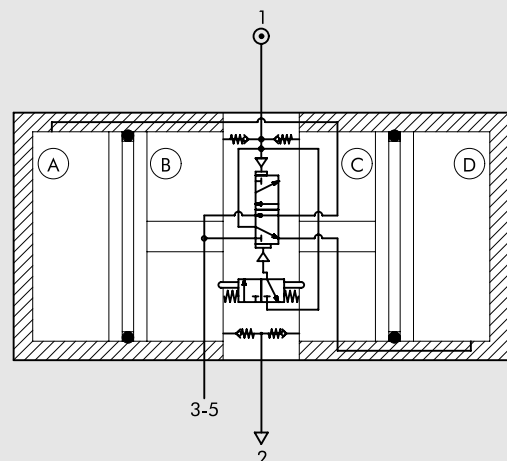

ACCESSORIES

COMPONENTS

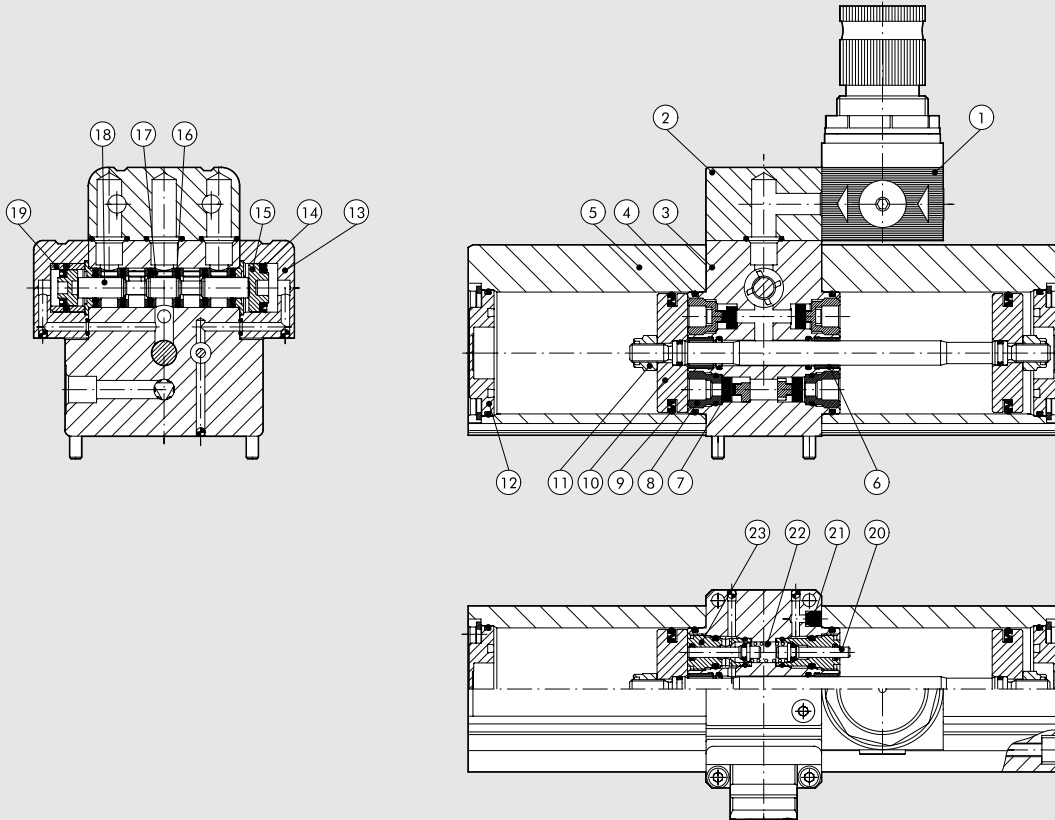

- ① PRESSURE REGULATOR (for 9002200 - 9002600 only)
- ② INTERFACE BLOCK (for 9002200 - 9002600 only):
anodized aluminium
- ③ CENTRAL BODY: anodized aluminium
- ④ OR SEAL: NBR rubber
- ⑤ BARREL: anodized aluminium alloy section
- ⑥ GUIDE BUSHING: steel strip with bronze and PTFE insert
- ⑦ POPPET: NBR rubber
- ⑧ CHECK VALVE: brass
- ⑨ PISTON GASKET: NBR rubber
- ⑩ PISTON: aluminium
- ⑪ SELF-LOCKING NUT: stainless steel

- ⑫ CYLINDER BASE: anodized aluminium
- ⑬ VALVE CONTROL: anodized aluminium
- ⑭ VALVE CONTROL GASKET: NBR rubber
- ⑮ VALVE PISTON: technopolymer
- ⑯ GASKET: NBR rubber
- ⑰ SPACER: technopolymer
- ⑱ SPOOL: nickel-plated aluminium
- ⑲ DIFFERENTIAL BUSHING: brass
- ⑳ PUSHER: stainless steel
- ㉑ SILENCER: technopolymer
- ㉒ SPRING: stainless steel
- ㉓ GUIDE BUSHING: brass

MOUNTING

On a wall using the M4 x 40 - M6 x 10 screws provided with the Booster.

On a panel using M5 - M8 screws.

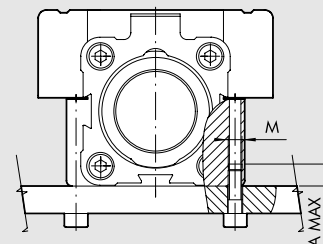
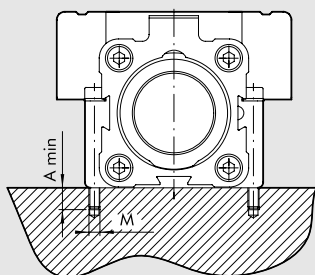

	Ø 40	Ø 63
A	8	12
M	M4	M6

	Ø 40	Ø 63
A	8	10
M	M5	M8

TANK FILLING CURVES

WITHOUT REGULATOR

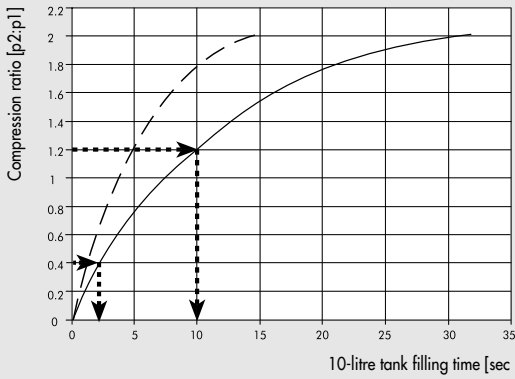

WITH REGULATOR

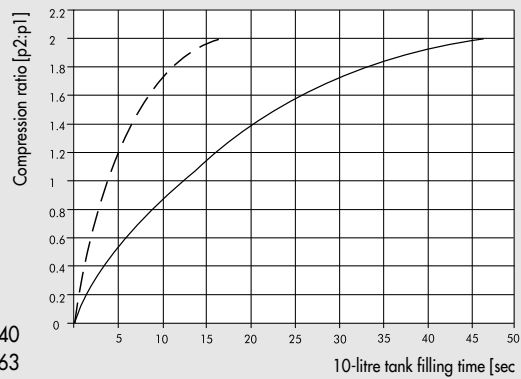

The graphs refer to the filling of a 10-litre tank and show the ratio of outlet to inlet pressure (= p2:p1) as a function of time (sec). The graphs are valid for any inlet pressure between 2 and 10 bar.

The following formula can be used to calculate the time t (sec) required to switch from pressure ratio 1 to pressure ratio 2 in a tank of volume V (litres):

$$t = \frac{V (t_2 - t_1)}{10}$$

where t1 and t2 are the times shown on the x-axis, corresponding to ratios 1 and 2.

E.g.

$$1 = 0.4 \Rightarrow t_1 = 2.5 \text{ sec}$$

$$2 = 1.2 \Rightarrow t_2 = 10 \text{ sec}$$

The time required to switch from 1 to 2 with a 25-litre tank is:

$$t = \frac{25 (10 - 2.5)}{10} \text{ sec} = 18.75 \text{ sec}$$

FLOW CHARTS

WITHOUT REGULATOR ø 40

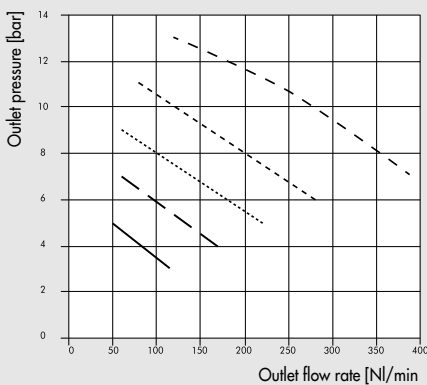

WITH REGULATOR ø 40

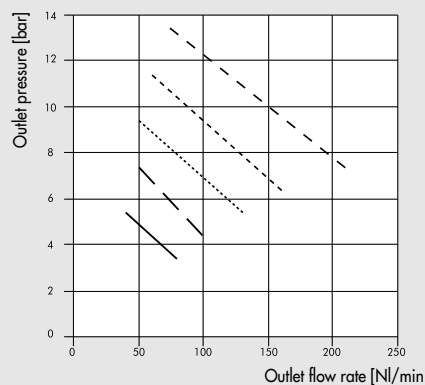

INLET PRESSURE	
---	p1 = 7 bar
- - -	p1 = 6 bar
.....	p1 = 5 bar
----	p1 = 4 bar
_____	p1 = 3 bar

WITHOUT REGULATOR ø 63

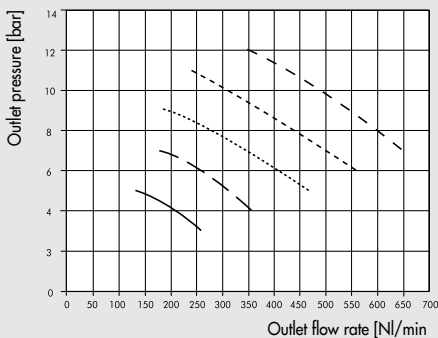

WITH REGULATOR ø 63

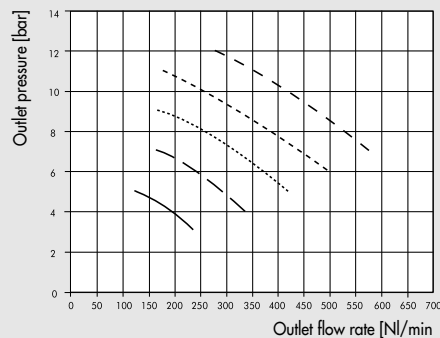

PRESSURE MULTIPLIER (BOOSTER Ø 40)

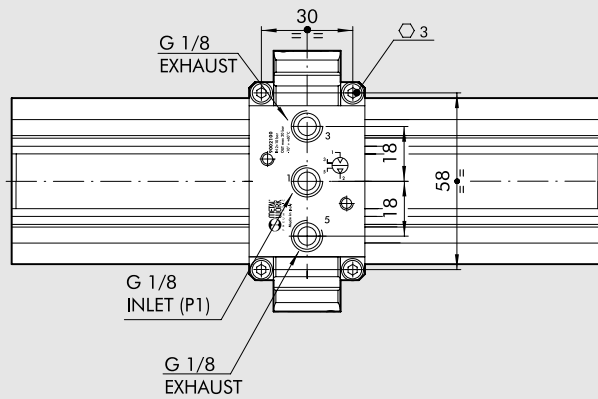
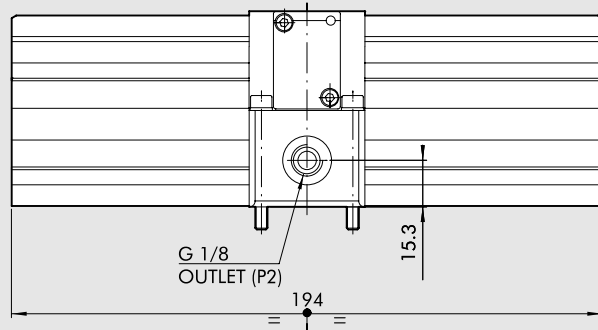
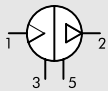
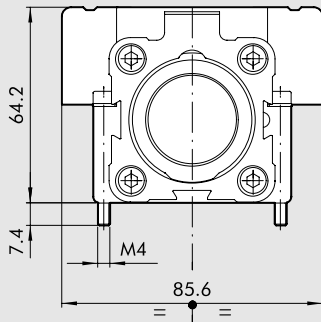

Code	Description
9002100	Booster Ø 40

PRESSURE MULTIPLIER (BOOSTER Ø 63)

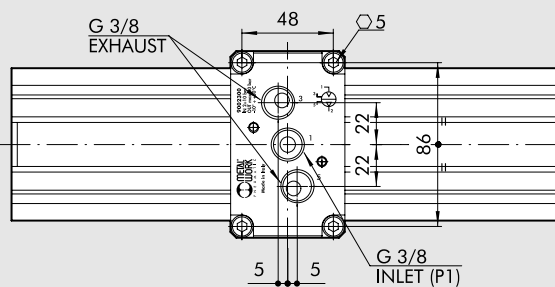
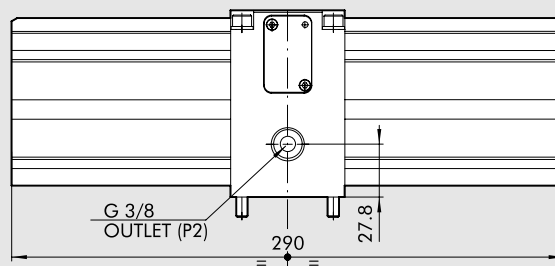
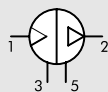
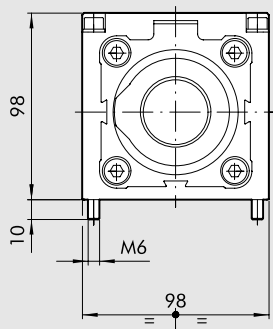

Code	Description
9002300	Booster Ø 63

PRESSURE MULTIPLIER (Ø 40 BOOSTER WITH REGULATOR)

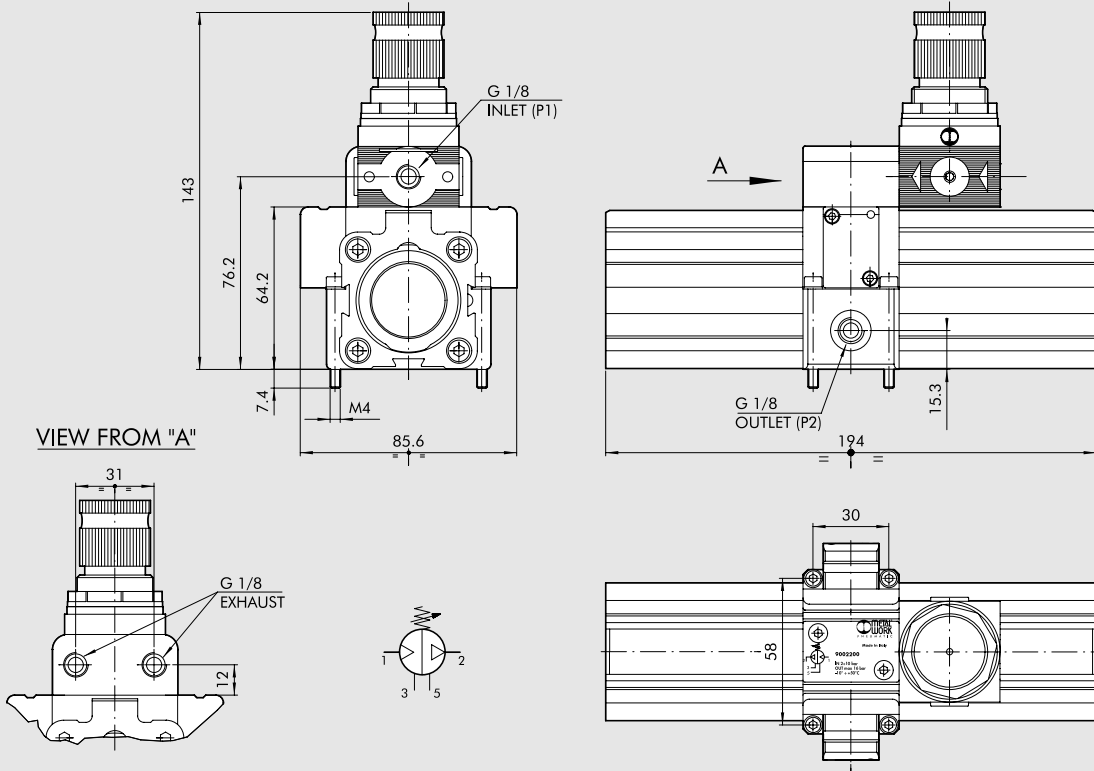

Code	Description
9002200	Booster ø 40 with regulator

PRESSURE MULTIPLIER (Ø 63 BOOSTER WITH REGULATOR)

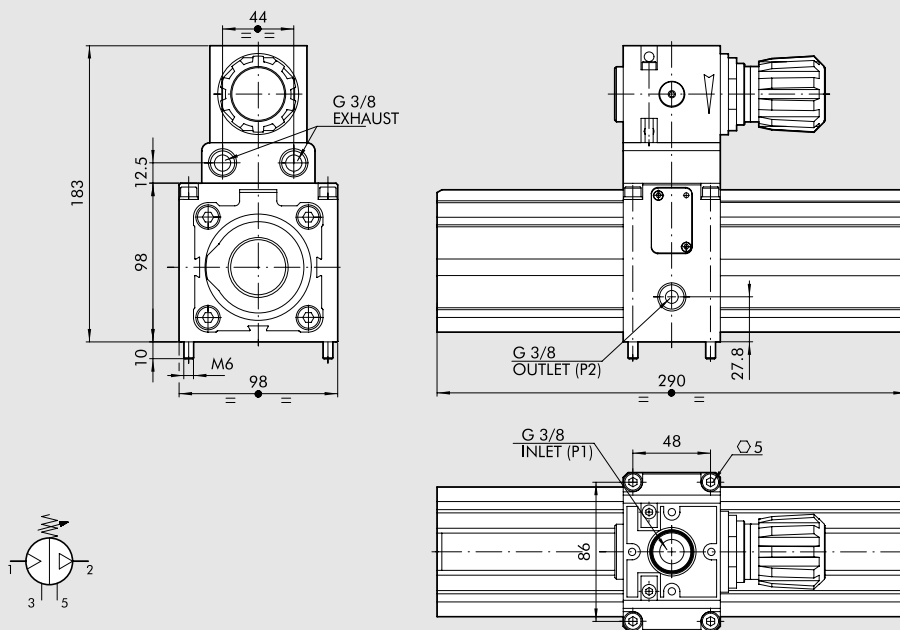

Code	Description
9002600	Booster ø 63 with regulator

ACCESSORIES

Ø 63 REGULATOR UNIT

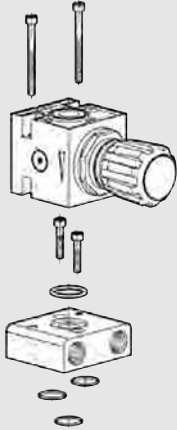

Code	Description
9002380	Ø 63 regulator unit

Note: supplied with 4 screws, 4 o-ring

Ø 40 REGULATOR UNIT

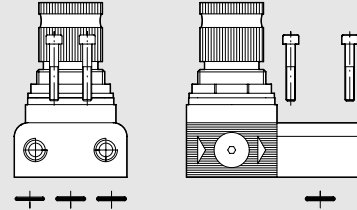

Code	Description
9002180	Ø 40 regulator unit

Note: Supplied with 2 screws, 3 O-ring

PRESSURE GAUGE

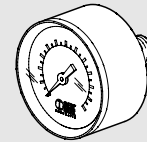

Code	Description
9700101	M 40 1/8 12

MW SPL-F SILENCER FOR BOOSTER Ø 40

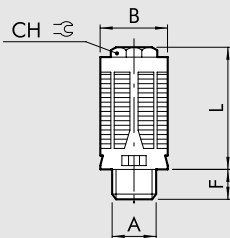

Code	A	B +0.2	F +0.5	L +3%	CH
W0970530072	G1/8	16.3	85.5	29	10

Materials:
Black acetal resin
Felt

Features:
Pmax: 12 bar
Temp.: -10°C to +60°C

MW SCQ SILENCER FOR BOOSTER Ø 63

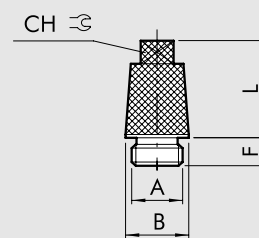

Code	A	B +0.2	F +0.5	L +3%	CH
W0970530014	G3/8	19	8.5	29.2	10

Materials:
Nickel-plated brass
Sintered nickel-plated bronze

Features:
Pmax: 12 bar
Temp.: -10°C to +80°C

SILENCER FLOW GRAPH

MW SPL-F

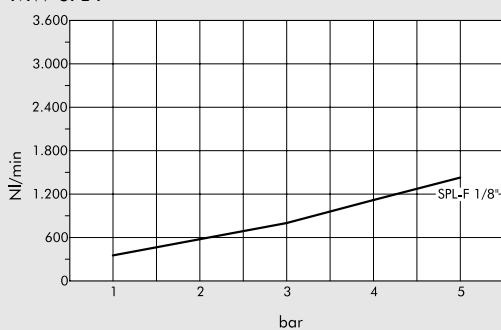

MW SCQ



SPARE PARTS

SET OF GASKETS

Ø 40

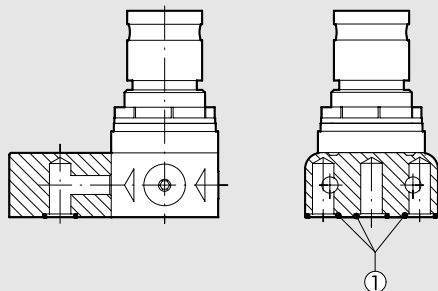

Ø 63

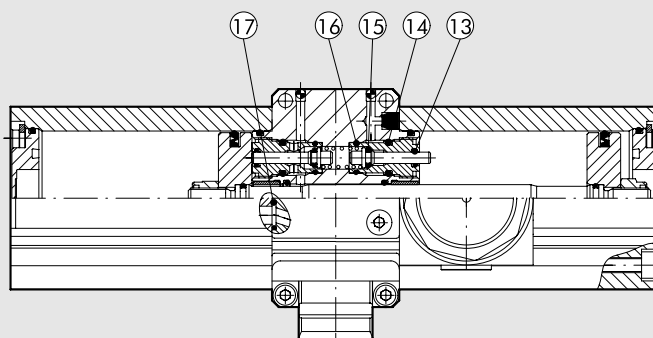
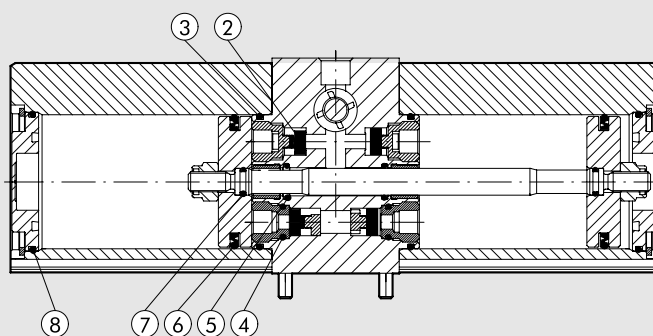
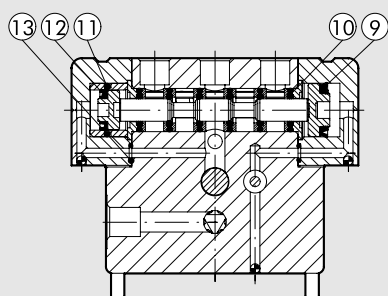
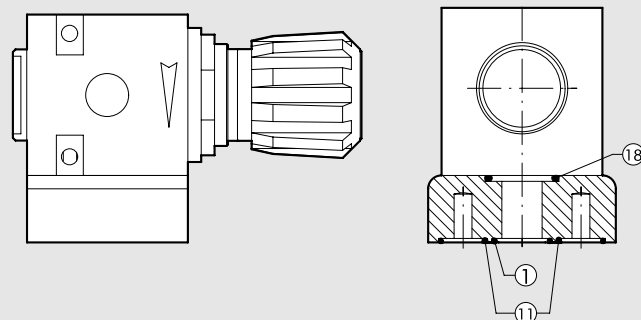

Code	Description
9002190	Set of gaskets for Ø 40 Booster (includes all gaskets numbered 1 to 17)
9002390	Set of gaskets for Ø 63 Booster (includes all gaskets numbered 1 to 18)